

PRODUCT INFORMATION PACKET



Model No: 256THFNA19050AA

Catalog No: 811557.00

20HP..1775RPM.256.TEFC./V.3PH.60HZ.CONT.NOT.40C.1.15SF.RIGID.IEEE 841.256THFNA19050AA
IEEE 841



Regal and Leeson are trademarks of Regal Beloit Corporation or one of its affiliated companies.

©2018 Regal Beloit Corporation, All Rights Reserved. MC017097E





Nameplate Specifications

Output HP	20 Hp	Output KW	14.9 kW
Frequency	60 Hz	Voltage	460 V
Current	24.1 A	Speed	1775 rpm
Service Factor	1.15	Phase	3
Efficiency	93 %	Duty	Continuous
Insulation Class	F	Design Code	B
KVA Code	G	Frame	256T
Enclosure	Totally Enclosed Fan Cooled	Overload Protector	No
Ambient Temperature	40 °C	Drive End Bearing Size	309
Opp Drive End Bearing Size	210	UL	Recognized
CSA	N	CE	Y
IP Code	56		

Technical Specifications

Electrical Type	Squirrel Cage Inverter Rated	Starting Method	Line Or Inverter
Poles	4	Rotation	Reversible
Mounting	Rigid base	Motor Orientation	HORIZONTAL
Drive End Bearing	BALL	Opp Drive End Bearing	BALL
Frame Material	Cast Iron	Shaft Type	T
Overall Length	25.27 in	Frame Length	12.25 in
Shaft Diameter	1.625 in	Shaft Extension	4 in
Assembly/Box Mounting	F1/F2 CAPABLE		
Outline Drawing	B-SS203002LE-1225	Connection Diagram	A-EE7300-LE

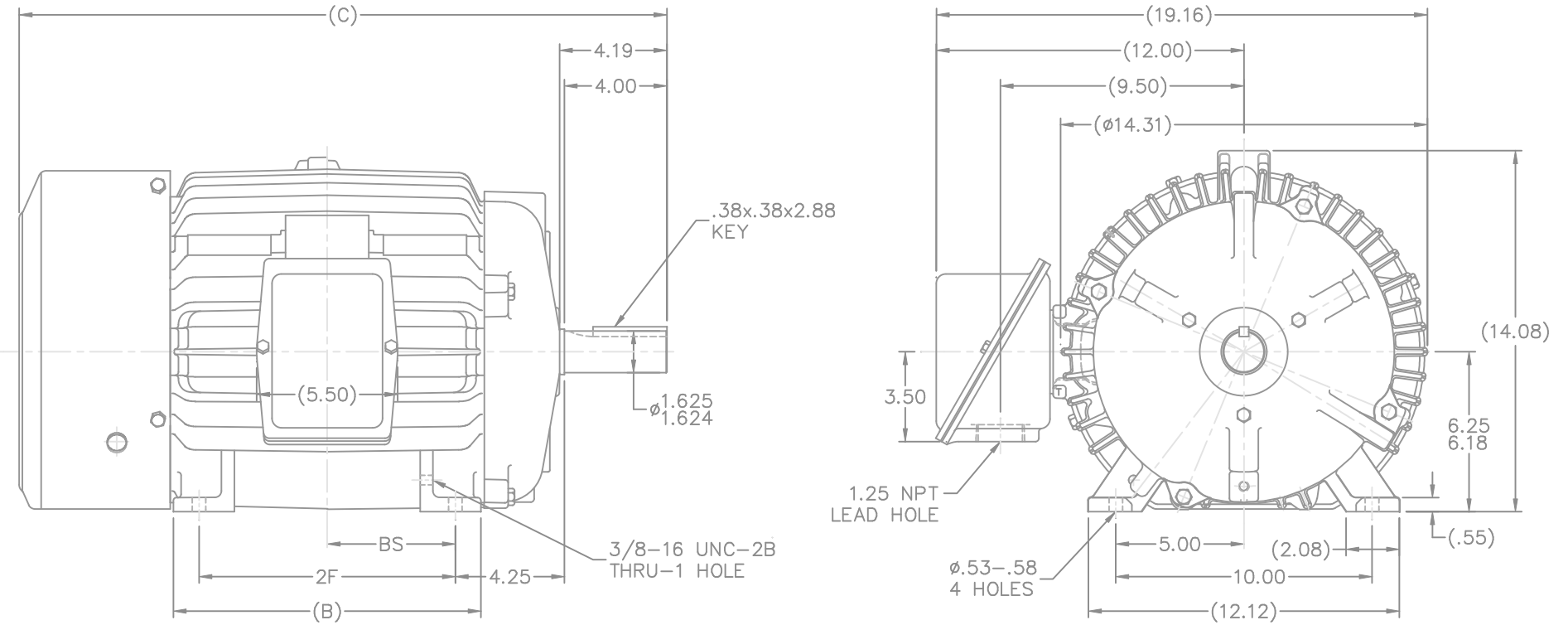

- NOTES:
 1. BOX CAN BE ROTATED ON ITS AXIS.
 2. BOX CAN BE MOUNTED ON OPPOSITE SIDE BY REMOVING BRACKETS AND TURNING FRAME 180°.
 3. NAMEPLATE TO BE READ FROM CONDUIT BOX SIDE OF MOTOR.

DASH	FRAME	B	C	2F	BS
1050	254T	10.25	23.52	8.25	4.12
1225	256T	12.00	25.27	10.00	5.00

		TOLERANCES UNLESS SPECIFIED		 ELECTRIC MOTORS GEARMOTORS AND DRIVES		DRAWN RJW 08-17-2007	
		DEC.	INCHES			CHK ML 08-17-2007	
		.X	±.1	TITLE OUTLINE		APPD DR 08-17-2007	
		.XX	±.03	250 FR. - BB - TS - STD.		SCALE 1=4	
		.XXX	±.005	MAT'L		REF	
		.XXXX	±.0005	FINISH		FMF MU81054	
NO.	REVISION	BY & DATE	CHK	ANG	±7'30"	PREV	
THIS DRAWING IN DESIGN AND DETAIL IS OUR PROPERTY AND MUST NOT BE USED EXCEPT IN CONNECTION WITH OUR WORK ALL RIGHTS OF DESIGN AND INVENTION ARE RESERVED THIS IS AN ELECTRONICALLY GENERATED DOCUMENT - DO NOT SCALE THIS PRINT				RFP	08-17-2007	CAD FILE	ss203002LE
				DIST	LB	SIZE	DRAWING NO. PAGE OF REV.
						B	SS203002LE

THREE PHASE - SINGLE VOLTAGE
MOTOR - CONDUIT BOX @ 'A'

TO REVERSE ROTATION:
INTERCHANGE ANY TWO LINE
LEAD CONNECTIONS

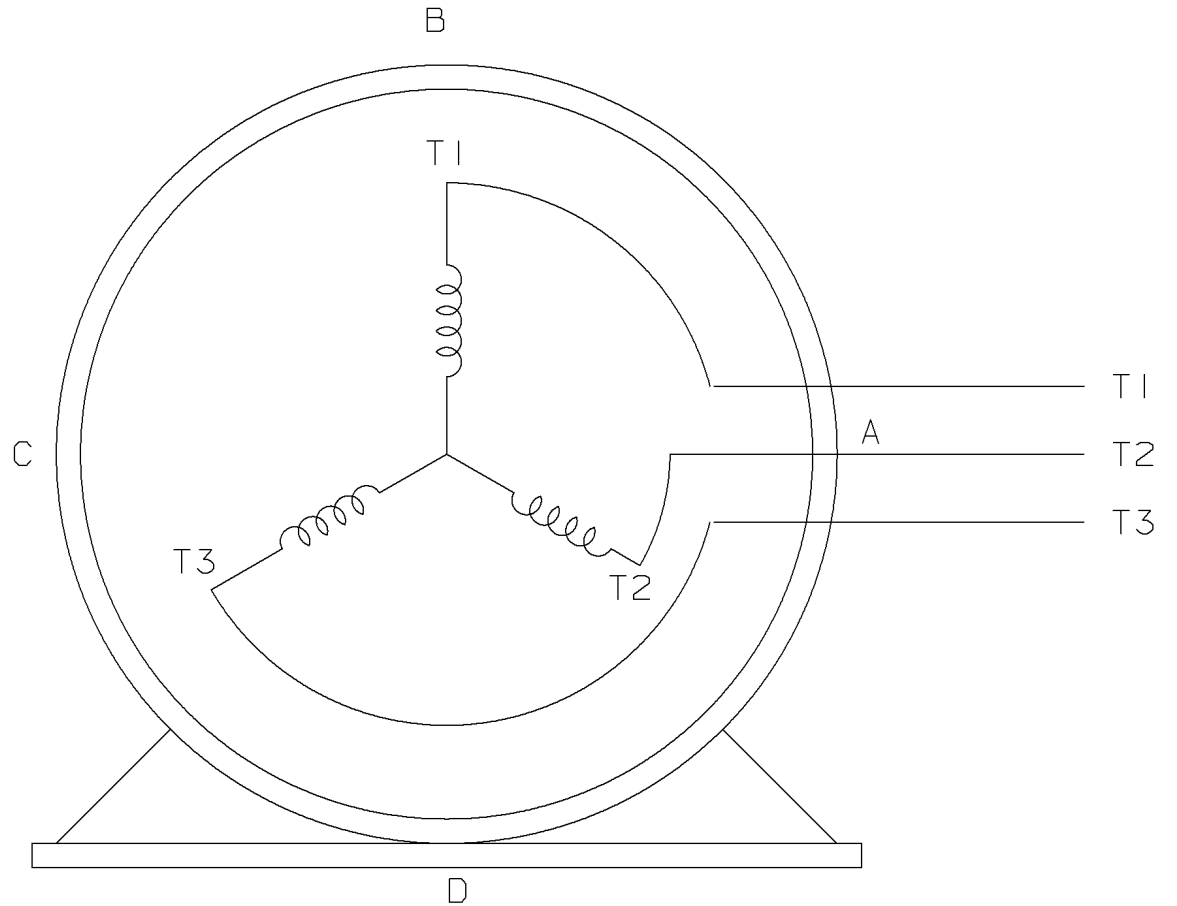

IF MOTOR HAS
6 LEADS

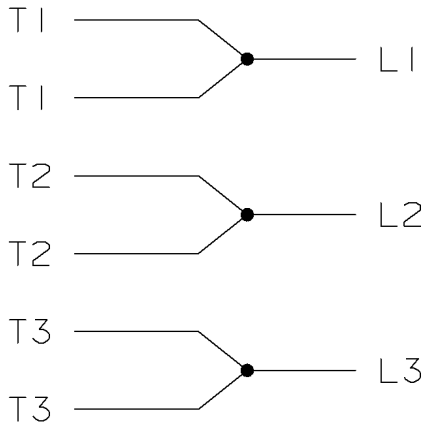

A-9806 DECAL

VIEW OF TERMINAL END

				TOLERANCES UNLESS SPECIFIED		 ELECTRIC MOTORS GEARMOTORS AND DRIVES	DRAWN MSG 05-22-2002			
				DEC.	TOLERANCE		CHK ML 05-22-2002			
				.X	± .1		APPD GK 05-22-2002			
				.XX	± .02		SCALE			
				.XXX	± .005		REF			
1	NEW DRAWING	MSG	05-22-2002	ML	.XXXX ± .0005	TITLE CONNECTION DIAGRAM SINGLE VOLT - 3Ø MOTOR	FMF			
NO.	REVISION	BY	DATE	CHK	ANG ± 7'30'	<input checked="" type="checkbox"/> SURFACE ROUGHNESS UNLESS SPECIFIED	MAT'L. FINISH	PREV		
THIS DRAWING IN DESIGN AND DETAIL IS OUR PROPERTY AND MUST NOT BE USED EXCEPT IN CONNECTION WITH OUR WORK. ALL RIGHTS OF DESIGN AND INVENTION ARE RESERVED. THIS IS AN ELECTRONICALLY GENERATED DOCUMENT - DO NOT SCALE THIS PRINT				PURCHASED		CAD FILE EE7300-LE	SHOP BOOK	SIZE	DRAWING NO.	REV.
				DIST WA - LB - WP - LM - BR - BY				A	EE7300-LE	I



Motor Load Data								
Load	0%	25%	50%	75%	100%	115%	125%	LR
Current (Amps)	8.5	10.5	14.0	18.5	24.1	27.0	30.0	138
Torque (ft-lb)	0.00	14.5	29.5	44.5	59.2	68.0	74.5	105
RPM	1800	1795	1785	1780	1775	1770	1760	0
Efficiency (%)		90.0	93.0	93.6	93.0	92.4	91.7	
P.F. (%)	8.5	51.0	72.0	81.0	84.0	84.5	85.0	40.0

Motor Speed Data						Information Block			
Speed (RPM)	LR	Pull-Up	BD	Rated	Idle	HP	Sync. RPM	Frame	Enclosure
0	0	900	1625	1775	1800	20.0	1800	256	TEFC
Current (Amps)	138	115	86.0	24.1	8.5				
Torque (ft-lb)	105	100	146	59.2	0.00				

Construction	TFN
Voltage	460 V
Frequency	60 Hz
Design	B
LR Code letter	G
Service Factor	1.15
Temp Rise @ FL	65 °C
Duty	CONT
Ambient	40 °C
Elevation	1,000 feet
Rotor/Shaft wk ²	3.2 lb-Ft ²
Ref Wdg	K2564164 NONE
Sound Pressure @ 1M	65 dB(A)
VFD Rating	CONSTANT 20:1
Outline Dwg	B-SS203002LE-1225
Conn. Diag	A-EE7300-1E
Additional Specifications:	
0	
EQUIV CKT (OHMS / PHASE)	
R1	R2
0.2670	0.2070
X1	X2
0.3900	1.4910
Xm	
	28.4000

